

# TURBO-SEPARATOR MODEL T10-3-315

## High Solids Capacity, Centrifugal Coolant Purification System

- Water Soluble Coolant
- Semi-synthetic Coolants
- Synthetic Coolants

The **T10-3-315** is a complete centrifuge system that removes solids and tramp oil from coolants. It discharges cleaned coolant into the clean tank, removes tramp oil to an oil tank, and solids are removed via a large easy-to-clean liner. Components include a 3 phase centrifuge, dirty and clean holding tanks, transfer and feed pumps, a coolant make-up system and automatic valves and controls.

The T10 series can be installed as a free-standing batch process unit, integrated with a single machine tool, or used on-line as a side stream processing unit for large central sumps. Processing capacity is up to 90 GPH.

The **T10-3-315** is the easiest commercially available centrifugal coolant recycling system to operate and maintain.

Turbo-Separator coolant recycling units operate at high gravitational forces to pull loosely and mechanically emulsified tramp oil away from good coolant. The separator's large solids capacity and easy-to-clean bowl design make it ideal for ferrous, non-ferrous, glass, graphite and ceramic applications. Solids can be removed down to 2 micron.

The **T10-3-315** is a value priced coolant recycling system that will reduce coolant waste.



THE TURBO-SEPARATOR T10-3-300

## FEATURES

- 3450 RPM rotating speed, generating 1180 G's
- Unique bowl design for ease of solids removal
- Heavy duty plastic liner with handles for ease of removal
- Mixing in the dirty tank helps deliver all the contaminants to the centrifuge
- Available in corrosion-resistant materials
- Complete packaged system with automatic coolant make-up, tanks and pumps
- Uses no consumable media

## BENEFITS

- Increased production quality and consistency
- Reduced new coolant purchases
- Reduced disposal volume of reusable coolant
- Reduced machine tool sump maintenance and labor costs
- Reduced tooling costs



## T10-3-315 LAYOUT

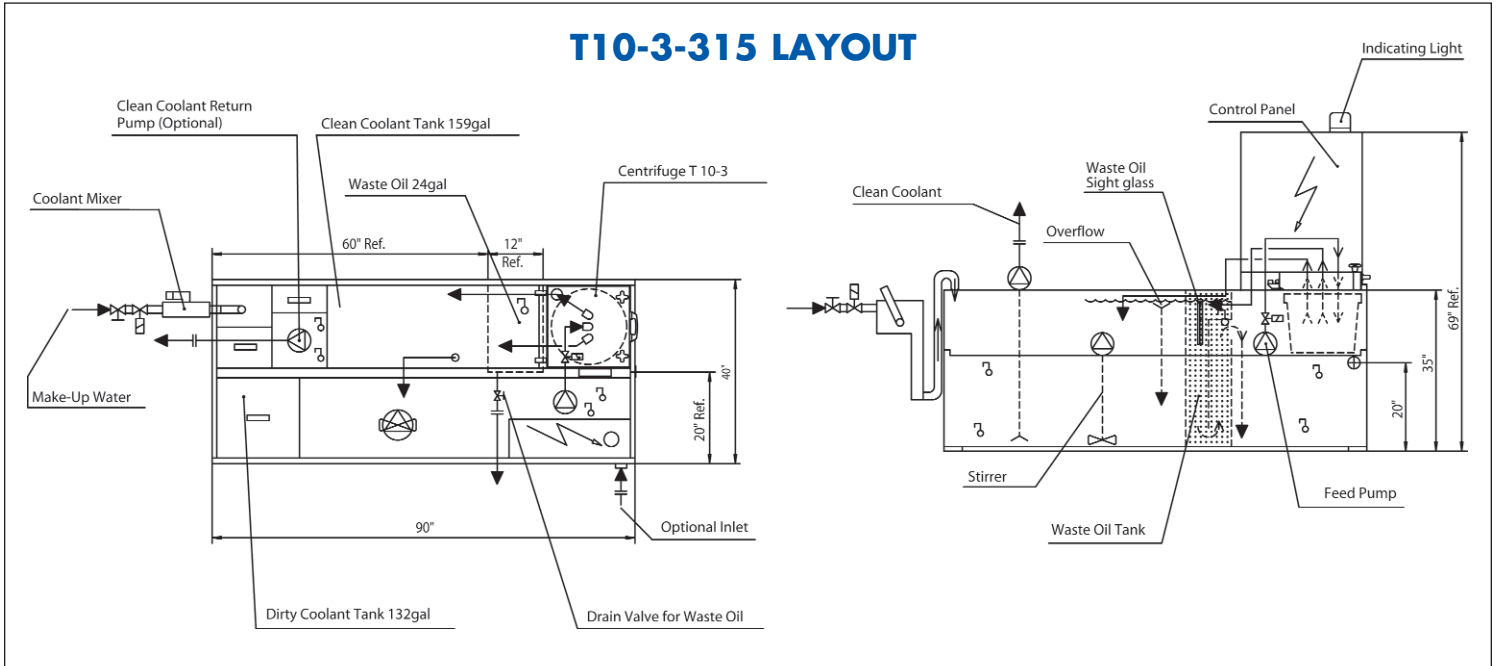

### GENERAL SPECIFICATIONS

DIMENSIONS (L x W x H)	92" x 40" x 70"
SHIPPING DIMENSIONS (L x W x H)	100" x 47" x 80"
MACHINE WEIGHT	1,400 lbs.
SHIPPING WEIGHT	1,765 lbs.
MAXIMUM FLOW	90 GPH
ROTOR VOLUME	2.4 gal.
SLUDGE CAPACITY/CLEAN OUT	1.0 gal. / 10 lbs.
SLUDGE LINER (D x H)	11" x 8"
ROTOR RPM	3,450
ROTOR MOTOR	3 HP
MIN. INLET HEIGHT	4"
TANK CAPACITY (Dirty)	132 gal.
TANK CAPACITY (Clean)	159 gal.
DECANT OIL TANK	24 gal.
INLET	3"
OUTLET	3/4"
SUPPLY PUMP (Optional)	20-30 GPM
SUPPLY PUMP (Optional)	40-200 PSI

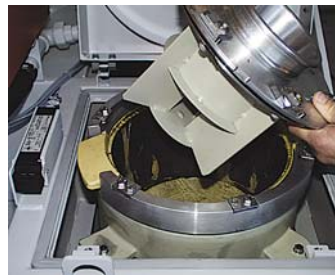

1.



2.



3.



4.

### Solids Removal from the T10-3

The separated sludge can be quickly and easily removed from the T10:

1. The centrifuge is switched off, and the housing and rotor cover are removed by disengaging the quick-locks.
2. The filled sludge basket is removed.
3. The cleaned sludge basket is re-installed.
4. The rotor and housing cover are re-installed, and the centrifuge is switched on.



23 Walpole Park South  
Walpole, MA 02081-2558 USA  
Telephone (508) 660-9150  
Fax (508) 660-9151  
E-mail sales@sanborntechnologies.com

[www.sanborntechnologies.com](http://www.sanborntechnologies.com)

All specifications in this datasheet are subject to change without notice.  
Copyright 2004 by North American Filtration of Massachusetts, Inc.

REV-012004